

MACHINE BUILDING

МАШИНОБУДУВАННЯ

UDC 621.86.078.62

I. Sydorenko, DSc, Prof.,
E. Kravtsov, PhD, Assoc. Prof.,
I. Prokopovych, DSc, Assoc. Prof.,
M. Korolkova,
S. Dmitrieva

Odessa National Polytechnic University, Shevchenko Ave. 1, Odessa, Ukraine, 65044; e-mail: sii@opu.ua

REDUCING THE RELIABILITY OF EQUIPMENT AS A RESULT OF THE REDUCTION OF THE CULTURE OF PRODUCTION

І.І. Сидоренко, Е.Д. Кравцов, І.В. Прокопович, М.В. Королькова, С.Ю. Дмитрієва. Зниження надійності обладнання як результат зниження культури виробництва. У роботі проведено дослідження причин поломки несучої конструкції (рами) і елементів трансмісії вібраційного конвеєра, розробленого ЗАТ ІПЦ «Сігурд» (м. Одеса) і знаходиться в експлуатації на одному з підприємств України. В результаті проведених досліджень були виявлені місця руйнувань, їх характер, і зроблено розрахунок силових факторів, що викликають ці руйнування. Розрахунки проводилися на основі розрахункової схеми, складеної за геометричними параметрами зруйнованих елементів несучої конструкції і допустимих напружень для їх матеріалів. Розрахунки зводилися до визначення граничних умов, що призводять до руйнування того чи іншого елемента і вузла, і їх порівнянні з зусиллям, яке розвиває трансмісія. Так само був зроблений аналіз кінематики і динаміки вібраційного конвеєра, для чого було розроблено його тривимірну комп'ютерну модель, на основі якої проведені дослідження. Проведені розрахунки і аналіз показали, що причиною руйнування елементів конструкції з'явилися порушення в кінематики пристрою. Встановлено, що на етапах проектування і виготовлення даного обладнання помилок не було, а проблеми виникли під час складання і монтажу, оскільки не виконувалися основні вимоги по геометрії, як ланок самого пристрою, так і місць їх з'єднань. Експертна оцінка прийшла до висновку, що на даному підприємстві має місце низька культура виробництва і як наслідок, неякісна організація виробничого процесу. Між підрозділами, які виконують роботи, відсутня взаємодія, немає належного контролю над виконавцями, а також відсутня необхідна кваліфікація інженерно технічного персоналу. Розроблений комплекс заходів, що включає в себе проектування, виготовлення і застосування мірного (каліброваного) інструменту і оснастки, поряд з навчанням персоналу дозволив виправити ситуацію, що склалася, і отримати працездатне обладнання.

Ключові слова: вібраційний конвеєр, кінематичні характеристики, надлишковий зв'язок, ефект «само запирання», культура виробництва

I. Sidorenko, E. Kravtsov, I. Prokopovych, M. Korolkova, S. Dmitrieva. Decreased reliability of equipment as a result of lower production culture. The study investigates the causes of breakdown of the supporting structure (frame) and transmission elements of the vibratory conveyor, developed by "Sigurd" CJSC (Odessa) and is in operation at one of the enterprises of Ukraine. In result of the studies, the places and nature of destruction were identified, as well as the force factors causing these destructions were calculated. The calculations were carried out at the basis of a calculation scheme compiled by the geometric parameters of the destructible elements of the supporting structure and the permissible stresses for their materials. The calculations were reduced to determining the ultimate forces leading to the destruction of the element and assembly, and their comparison with the effort developed by the transmission. In addition, an analysis of the kinematics and dynamics of the vibration conveyor was made, for which its three-dimensional computer model was developed. Studies were conducted on its basis. The calculations and analysis showed that the cause of the destruction of structural elements was a violation in the kinematics of the device. It was found that there were no errors at the stages of designing and manufacturing of this equipment, and problems arose during assembly and installation, as the basic geometry requirements of both the units of the device and their connection points were not fulfilled. An expert assessment concluded that the enterprise has a low production culture and, as a consequence, a poor quality organization of the production process. There is no interaction between the units performing the work; there is no proper control over the contractors, as well as the necessary qualifications of the engineering and technical personnel. The developed set of measures, which includes the design, manufacture and use of measuring (calibration) tools and equipment, along with staff training, made it possible to rectify the current situation and get efficient equipment.

Keywords: vibration conveyor, kinematic characteristics, excessive communication, self-locking effect, production culture

DOI: 10.15276/opu.3.59.2019.01

© 2019 The Authors. This is an open access article under the CC BY license (<http://creativecommons.org/licenses/by/4.0/>).

Introduction. In production the effective solution of technological problems largely depends on the productivity of the equipment used. Every year the growing requirements for the intensification of the technological process theoretically require the simultaneous replacement of all elements of the technological chain with new, more productive ones. However, in practice, the presence of a constraining economic factor determines the replacement one or more elements with new ones. Such a solution inevitably requires increasing the productivity of the remaining elements of the chain, which in this case should have a certain margin for this indicator. Obviously, there is a close relationship between a certain margin in terms of productivity and equipment reliability. Given this circumstance, it should be noted that ensuring the reliability of the equipment itself is a very complex integrated task. Its solution are connected with a series of events that are held both at the stage of equipment design, and at the stages of its manufacture, assembly and operation. Moreover, highlighting the priority stage, given their close relationship, is practically possible. Errors at any of these stages can cause malfunctions in the equipment, which lead to undesirable technological interruptions for repair or commissioning. One of the examples characterizing the reliability problem as complex is the experience of designing, manufacturing, operating and repairing a vibrating conveyor developed by “Sigurd” CJSC (Odessa). This vibration sifter is a vibration conveyor with a rubber-metal elastic system and an eccentric drive with a rigid connecting rod. It is designed to move with simultaneous screening of the load evenly distributed over the transport tray in the form of a fine granular sheet fraction (Fig. 1). The weight of an empty thin-walled transport tray measuring 3.5×1 m is 200 kg, the weight of the balancer is 300 kg. The total mass of the cargo on the transport tray in the technological cycle is not more than 8...12 kg. Despite the insignificant technological load and relatively small masses of the moving parts of the vibrating conveyor, during its operation at one of the enterprises of Ukraine there was a periodic disruption of its operation. Disruption in performance was manifested in the form of destruction of the supporting structure (frame) and transmission elements with a frequency of 1 failure in 1.5...2 months. On-site repairs did not completely repair this kind of damage. The last three breakdowns of the frame within one month led to the fact that this equipment was decommissioned before finding out the possible causes of its malfunction and their elimination.

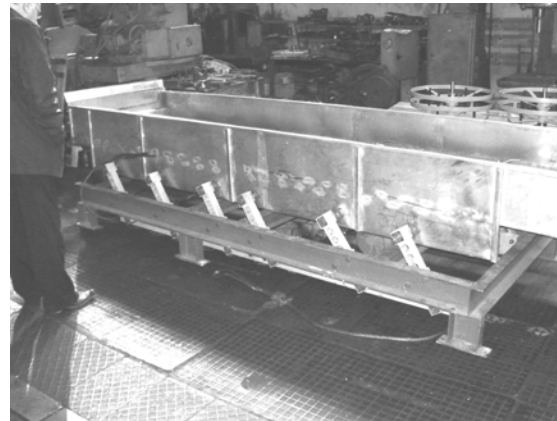

Fig. 1. Vibrating conveyor “Sigurd” CJSC

Analysis of publications. There are many methods for diagnosing equipment malfunctions and searching for the causes of their occurrence [1, 2, 3]. Given the specifics of hoisting and transporting equipment, to which the considered vibration conveyor can be attributed, the main causes of malfunctions are considered to be equipment overload, causing excess allowable loads on its metal structures or unauthorized attempts to increase its productivity by increasing the speed of the actuator, which causes dynamism load exceeding calculated [4, 5, 6, 7].

Sometimes the cause of the malfunction is the error in the handling equipment associated with the human factor [8, 9, 10]. The main causes of malfunctions of vibrating conveyors are the mistakes made at the stages of design and operation [5, 8, 9].

An unsolved problem area is a scientifically based search for the causes of breakdowns of existing equipment and development of recommendations for their elimination.

The aim of the study is a structural, kinematic and strength analysis of the existing structure, which determines the possible errors in its design, assembly, operation and repair.

Results. To find out the possible causes of breakdowns of the vibrating conveyor, an external check of its supporting structure was carried out, in which several damages were recorded. The nature

of the damage was previously determined by external signs. These are the presence of cracks, the state of the surface of the cracks, etc.

External examination revealed:

– welded joints of the profile (corner) for fastening the drive elements (connecting rod and engine) with transverse bearing profiles (channel) were destroyed. The presence of the granular structure of the metal at the site of the cut and the absence of traces of rolling suggest that the failure was not fatigue in nature, but was most likely caused by a short-term excess of the allowable load, which led to the destruction of the welds (Fig. 2, *a*);

– the eye and the transverse beam of the balancers in the place of attachment of the connecting rod were destroyed, the type of destruction is not fatigue, it is likely that the permissible bending stresses are exceeded (Fig. 2, *b*);

– load-bearing profiles (channel) for fastening drive elements (support of the eccentric and engine) were destroyed, the place of destruction was the middle of the span, the type of destruction was not fatigue, bending stresses were clearly exceeded (Fig. 2, *c*);

– numerous fractures and tears of metal were detected in the supporting elements of the frame - the type of failure is not fatigue, it is obvious that the allowable bending stresses or allowable tensile stresses are exceeded. In some cases, a loss of stability by the profile was observed (Fig. 2, *d*).

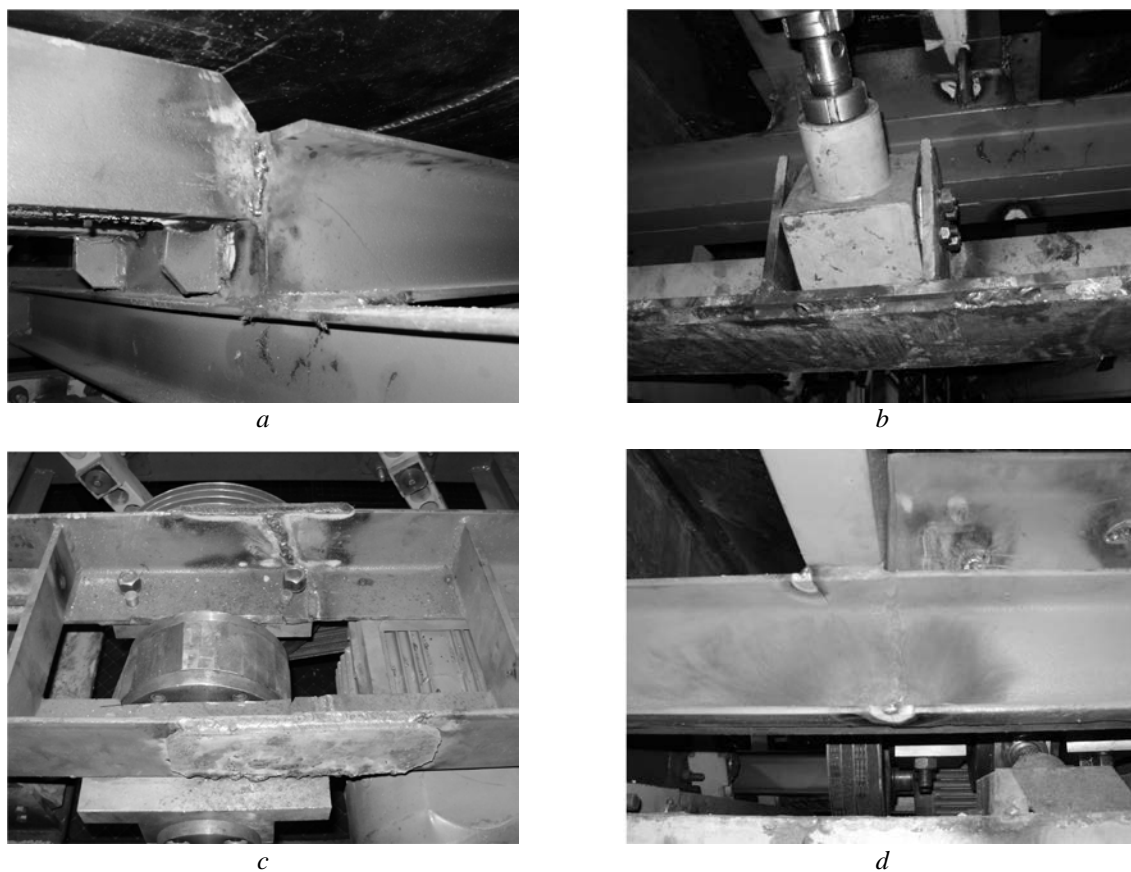

Fig. 2. Places and type of destruction of the supporting structure (frame) of the vibrating conveyor: destruction of the welds (a), destroyed transverse beam of the balancers in the place of attachment of the connecting rod (b); destroyed load-bearing profiles for fastening drive elements (c); numerous fractures and tears of metal (d)

Since the nature and location of the destruction were established, it was proposed to calculate the force factors that cause this destruction, with further clarification of the possible reasons for the occurrence of destruction. Taking into account the presence of geometric parameters of the object under consideration obtained by full-scale measurement, as well as the available data on the materials of its constituent elements, an appropriate calculation scheme was compiled (Fig. 3).

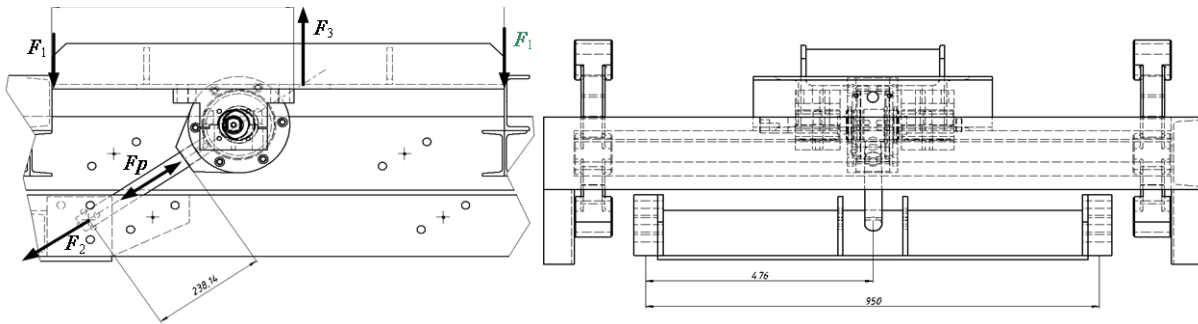

Fig. 3. Design scheme for determining power factors depending on the location and type of damage

Based on the specified calculation scheme, calculations were carried out to determine the ultimate forces leading to the destruction of a particular element and assembly, and their comparison with the installed transmission power. The main calculated dependencies and calculation results are summarized in the table (Table 1).

Table 1

Power factors and places of destruction of the vibrating screener design

Place of damage	Estimated dependence	The maximum design force leading to destruction	Theoretical destruction number
Welded joints of bearing corners with transverse channels (A)	$F_1 \geq A_s[\tau_s]$, A_s – total cutting area of fillet welds	$F_1 \geq 78$ кН	II
Crossbeam at the pusher mount	$F_2 \geq [\sigma_b]W/0.476$, W – crossbeam at the pusher mount	$F_2 \geq 65$ кН	I
Center profile (corner) for mounting drive elements	$F_3 \geq [\sigma_b]W/0.5$, W – cross section bending moment	$F_3 \geq 82$ кН	III
Connecting rod shaft	No calculation		
The theoretical force developed by the engine	$T_1 = P_1 \omega_1$; $T_2 = u T_1 \eta$; $F_p = T_2 e$, e – eccentricity	$F_p \approx 114270$ кН	

Analysis of the acts of breakdowns available at the enterprise and descriptions of the repair work carried out made it possible to establish the following chronology of real events. The first is the destruction of the transverse beam of the balancers. Repair measures consisted of both a welded joint of the destruction site and the installation of additional linings, which increased the cross-sectional area of transverse beam of the balancer by about 2 times. After the repair work relatively short period of time, the welded joints of the bearing profiles (corners) with transverse profiles (channels) were destroyed. Repair measures in this case consisted in mounting on the damaged element with the help of a welded joint of additional plates and stiffeners. At the same time, the total cross-sectional area (A_s) was increased approximately 3.5 times. The repairs also failed. The next day, after it was carried out, the destruction of the bearing profiles (corners) for mounting the drive elements. Repair measures in this case were reduced to installation on a damaged element using welded joint, additional plates and stiffening ribs. In this case, the moment of resistance to bending of the cross section (W) was increased by approximately 3 times.

The specified repair was also not the last, since new damage again began to appear in the places of previous repairs. Based on this, the equipment was stopped and decommissioned to establish the causes of breakdowns.

Comparing the results of the calculation with the repair data for this equipment, it is easy to see that:

– the application of the developed design scheme gives the correct result when assessing the priority of damage, and its use is quite acceptable in the further search for the causes of breakdowns;

– the effort developed by the transmission is not expended on the transmission of the working movement, but is directly transmitted to the supporting structure and leads to its destruction.

The latter circumstance allowed us to suppose that the failure in the supporting structure is associated with errors in the kinematics of the working movements of the equipment. That, in turn, may be the result of mistakes made at one of three stages: design, manufacture or assemblage.

To verify this assumption, a kinematic analysis of the presented vibration conveyor was performed (Fig. 4). A scraper conveyor with a rubber-metal elastic articulated system and a drive with a rigid connecting rod (Fig. 4, a), in accordance with the symmetry condition of the left and right parts of the device lever relative to its longitudinal axis, can be represented by the following kinematic scheme (Fig. 4, b).

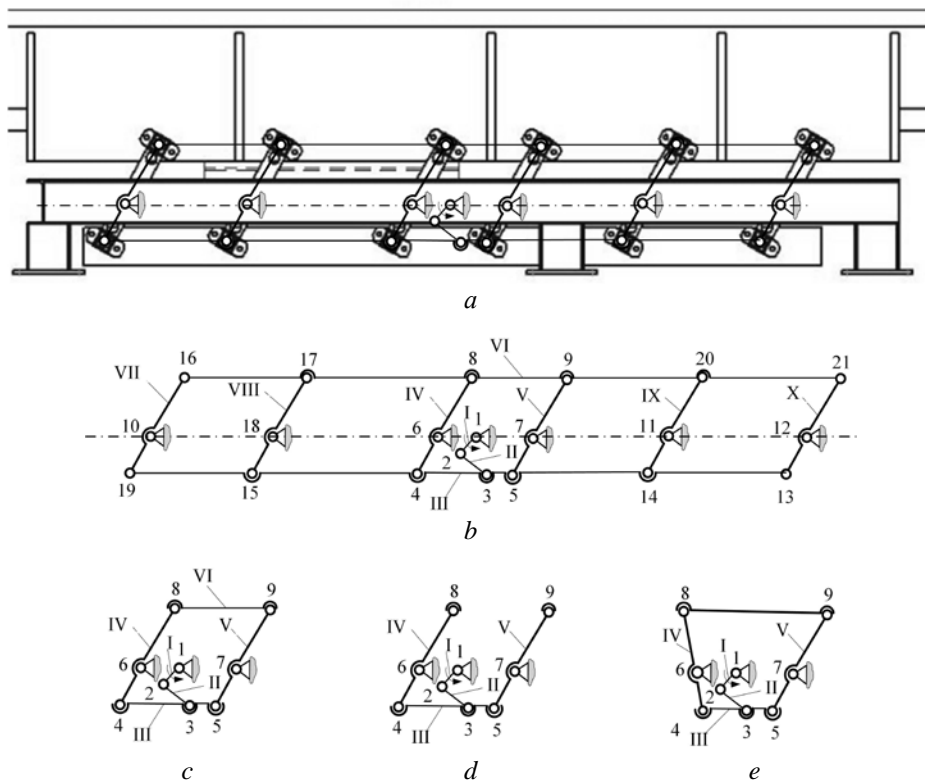

Fig. 4. Kinematic analysis of the vibrating conveyor: vibratory conveyor design (a); kinematic scheme (b); generatrix for the kinematic scheme (c); kinematic scheme rational mechanism (d); kinematic scheme “self-blocking” of the mechanism (e)

Such a kinematic scheme defines a flat articulated – lever mechanism, the degree of mobility of which can be calculated according to the Chebyshev formula [10, 11]:

$$W = 3n - 2p_5 - p_4 \pm q, \tag{1}$$

where n – number of movable links;

p_5 – the number of kinematic pairs of the 5th grade;

p_4 – the number of kinematic pairs of the 4th grade;

$\pm q$ – the number of excess bonds (mobility).

Given that the kinematic scheme (Fig. 4, c) is the generatrix for the kinematic scheme (Fig. 4, b), we determine the degree of mobility of the latter. Provided that $n = 6$, $p_5 = 9$, $p_4 = 0$ received:

$$W = 3n - 2p_5 - p_4 \pm q = 3 \cdot 6 - 2 \cdot 9 = 0, \tag{2}$$

$$(W=1 - 1=0 \rightarrow 1 - \text{engine и } q=-1 - \text{excess bond}).$$

The equality $W = 0$ (zero degree of mobility) indicates that the mechanism under consideration is a rigid frame. However, it is not. There is a classic example of a mechanism with excess coupling (excess coupling is a link whose presence or absence does not affect the laws of motion of other links in the mechanism, for example, links I, II, III, IV, V, VI from the rational mechanism (Fig. 4, *d*). As a rule, excess bond is introduced into the mechanism for structural reasons (in the design of the vibrating conveyor under consideration, the upper hopper is an excess coupling).

It should be noted that the possibility of the functioning of mechanisms with excessive bonds is regulated by strict requirements for its geometry. So, the non-compliance in the considered mechanism of the conditions of equality of sizes [10]:

$$l_{4-5} = l_{6-7} = l_{8-9}, \quad l_{4-6} = l_{5-7}, \quad l_{6-8} = l_{7-9}. \quad (3)$$

Will inevitably lead to the effect of “self-blocking” of the mechanism, that is, to its transition after selection of the gaps to the state corresponding to a rigid frame (Fig. 4, *e*).

The presence of a larger number of excess connections (levers designed to evenly distribute the load from the tray and the balancers on the supporting structure) additionally tightens the requirements for the geometric parameters of the conveyor parts. In this case, in addition to the requirements for the dimensions of the parts and their joints, the following rigid requirements are added to the location on the three parallel axes of the corresponding kinematic pairs: axis 1 – 16, 17, 8, 9, 20, 21; axis 2 – 10, 18, 6, 7, 11, 12; axis 3 – 19, 15, 4, 5, 14, 13.

Given all of the above, it was suggested that the most likely cause of permanent damage to the equipment presented is a violation of kinematics, which is caused by non-compliance with the basic requirements for the geometry of the device parts and their connection points at the design, manufacturing or installation stage.

To check the kinematics and dynamics of the vibrating conveyor according to the drawings provided by “Sigurd” CJSC, a computer three-dimensional model of the device frame was created in the CAD environment of Autodesk Inventor (Fig. 5). Using Autodesk Inventor dynamic modeling tools (Dynamic Simulation), we modeled the workflow of this device, which allowed us to establish the following:

- violations of the geometric parameters of structural elements and their connections that lead to “notches” or intersections of parts during operation were not detected;
- the balance of the mechanism is satisfactory, the masses of the counterweights are selected within the tolerance of ± 20 kg and do not cause significant dynamic loads;
- strength characteristics of structural elements and their joints according to the conditions of exceeding the rated loads and a half times are selected correctly.

There are a number of subjective comments on the design regarding some design decisions and the selected engine power, which, however, do not affect its overall operability.

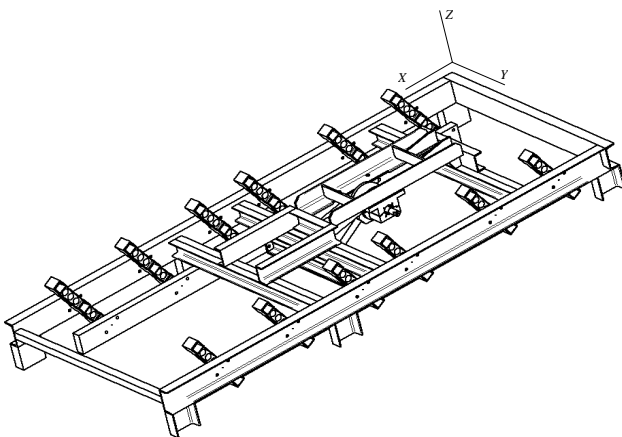

Fig. 5. 3D model of the frame of the vibrating conveyor

The presence of errors in the manufacture of the parts of the vibration conveyor is not detected also. This is explained by the fact that the requirements for “copyright control” are clearly complied with at the “Sigurd” CJSC production site. These measures consist in the fact that the design engineer necessarily controls the production and assembly of the elements of the design he developed.

Unfortunately, due to financial reasons, “author control” was not carried out at the enterprise on which the equipment in question was supplied. Assembling of the equipment and its transfer from the transport to the working position was carried out by outside organizations.

It is at this stage that some of the actions of the maintenance personnel that performed the assembly are established, which in the future will be the cause of the failure of the equipment presented. At the final stage of assembly, after the next repair, the following was established:

– the most of the levers of the device are connected to the balancers “in place”, which does not correspond to the places determined by the dimensions in the technical documentation. In this case, the face is not parallel to the leverage (Fig. 6, *a*), which is the main cause of the effect “self-blocking” according to expression (2) and violation of requirements (3);

– assembly of levers and axles with rubber bushings by means of pressing-in was done with violation of the conditions of perpendicularity of the fixing raft to the lever, which is defined in the technical documentation (Fig. 6, *b*). Obviously, this determined the fastening of the balancers “in place” and not in size.

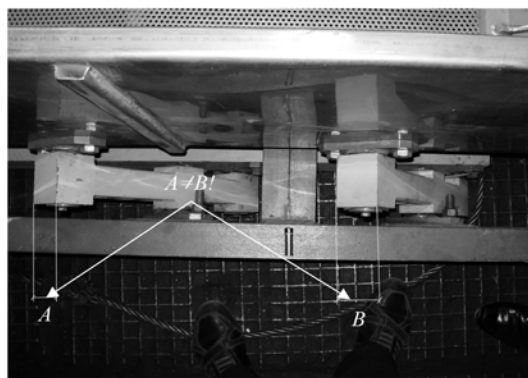

a



b

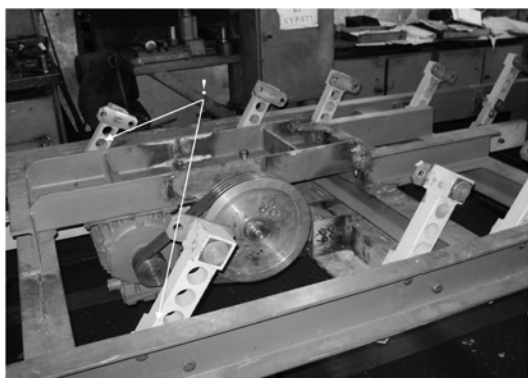

c

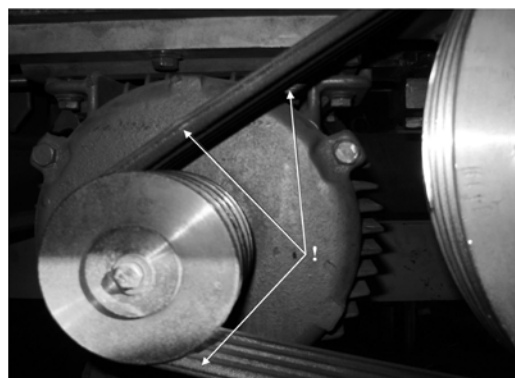

d

Fig. 6. Errors in the assembly of the vibration conveyor leading to the effect of “self-blocking”: end surfaces of levers are not parallel (*a*); violation of the conditions of perpendicularity of the fixing raft to the lever (*b*); uneven press of rubber bushings on a symmetrical pair of levers located next to the transverse beam of the balancer (*c*); traces of slipping of the drive belt (*d*)

In addition, in support of the “self-blocking” effect, as the alleged reason for the failure of the presented equipment, it is confirmed by a significant development in the form of punching rubber bushings on a symmetrical pair of levers located next to the transverse beam of the balancers (Fig. 6, *c*). The protective properties of the belt drive against overload (belt slipping took place) were negated by excessive belt tension (Fig. 6, *d*).

Since the main cause of the breakdowns was established, and it was associated with the low quality of the assembly, the customer was invited to perform this operation under the supervision of the designer.

At the same time, a number of works and activities were carried out, which allowed to significantly improve the build quality, namely:

– it was recognized to be rational to replace the rubber of the bushings with softer ones, which would allow less effort during assembly by pressing, which, along with the involvement of more qualified personnel, allowed to increase the accuracy of assembly;

– a set of measures was taken to improve the quality of assembly of levers and axles with rubber sleeves, as well as the levers of the device with balancers themselves, including the development and use of measuring (calibration) tools and equipment;

– appropriate training of personnel involved in the assembly.

The specified set of measures made it possible to assemble and set up equipment that has been working without complaints for more than eight months.

Conclusions. The conducted studies indicate that unfortunately, the industry of Ukraine is going through hard times. An example of the operation of this enterprise is a confirmation of this. All facts indicate a decrease in the culture of production and, as a consequence, the poor-quality organization of the production process. There is no interaction between the units performing work, there is no proper control over the executors, as well as the necessary competence of engineering and technical personnel. A particularly negative impact on the solution of a number of technical problems is provided by the low qualification of workers. It is primarily associated with omissions in the training of professional personnel, the lack of proper work experience, practical skills, as well as their inability to analyze and predict the situation.

Maintaining a production culture at the enterprise, which includes technological and performing discipline, professional and educational level of personnel, technological preparation of production are main factors of the international quality system.

Література

1. Александров М.П. Грузоподъемные машины. Москва : Изд-во МГТУ им. Н.Э. Баумана. Высшая школа, 2000. 552 с.
2. Ивашков И.И. Монтаж, эксплуатация и ремонт подъемно-транспортных машин. Москва : Машиностроение, 1991. 400 с.
3. Металлические конструкции. В 3-х т. Т. 1. Элементы конструкций / В.В. Горев., Б.Ю. Уваров, В.В. Филиппов и др.; Под ред. В.В. Горева. 2-е изд., перераб. и доп. Москва : Выш. Шк., 2001. 551 с.
4. Волков Д. П. Строительные машины и средства малой механизации. Москва : Мастерство, 2002. 480 с.
5. Иванченко Ф. К. Конструкция и расчёт подъемно-транспортных машин. 2-е изд. перераб. и доп. Киев : Выща шк. Головное изд-во, 1988. 424 с.
6. Лепеш Г.В., Куртов В.Н., Мотылев Н.Г. Оперативный контроль и диагностика оборудования. *Технико – технологические проблемы сервиса*. 2009. №3(9). С. 8–16.
7. Конвейеры: Справочник / Р.А. Волков, А.Н. Гнутов, В.К. Дьячков и др, Под общ. ред. Ю.А. Пертена. Ленинград : Машиностроение, 1984. 367 с.
8. Hoepfner D. W. Industrial Significance of Fatigue Problems. *In Fatigue and Fracture*. 2005. Vol. 19. P. 47–58.
9. Dyr T. Model Particle Velocity on a Vibrating Surface. *Physicochemical Problems of Mineral Processing*. 2002. Vol. 36. P. 147–157.
10. Кіницький Я.Т. Теорія механізмів і машин. Київ : Наукова думка, 2002. 660 с. ISBN 966-00-0740-X.
11. Бучинський М.Я., Основи творення машин. Харків : Вид-во «НТМТ», 2017. 448 с. ISBN 978-966-2989-39-7.

References

1. Alexandrov, M.P. (2000). *Hoisting machines*. Moscow: Publishing house of MGTU im. N.E. Bauman, "Visshaya shkola".
2. Ivashkov, I.I. (1991). *Installation, operation and repair of hoisting-and-transport machines*. Moscow: Mashinostroenie.
3. Gorev, V.V., Uvarov, B.Yu., & Filippov V.V., et al. (2001). *Metal structures*. In 3 vols. T. 1. Elements of structures. V.V. Grief. (Ed.). Revised. and add. Moscow: Vissh. shk.

4. Volkov, D.P. (2002). *Construction machinery and means of small mechanization*. Moscow: Masterstvo.
5. Ivanchenko, F.K. (1988). *Design and calculation of hoisting-and-transport machines*. 2nd ed. reslave. and add. Kyiv: Visha shk. Golovnoe izd-vo.
6. Lepesh, G.V. (2009). Operational control and equipment diagnostics. *Technical and technological problems of service*, 3, 8–16.
7. Volkov, R.A., Gnutov, A.N, & Dyachkov, V.K. at el. (1984). *Conveyors: Reference book*. Yu.A. Perten (Ed.). Leningrad: Mashinostroenie.
8. Hoepfner, D.W. (2005). Industrial Significance of Fatigue Problems. *In Fatigue and Fracture*, 19, 47–58.
9. Dyr, T. (2002). Model Particle Velocity on a Vibrating Surface. *Physicochemical Problems of Mineral Processing*, 36, 147–157.
10. Kinitsky, J.T. (2002). *Theory of mechanisms and machines*. Kyiv: Naukova dumka, ISBN 966-00-0740-X.
11. Buchinsky, M. (2017). *Fundamentals of machine creation*. Kharkiv: NTMT Edition, ISBN 978-966-2989-39-7.

Сидоренко Ігор Іванович; Sydorenko Ihor, ORCID: <https://orcid.org/0000-0003-1840-4313>

Кравцов Едуард Давидович; Kravtsov Eduard, ORCID: <https://orcid.org/0000-0002-0830-3212>

Прокопович Ігор Валентинович; Prokopovych Ihor, ORCID: <https://orcid.org/0000-0002-8059-6507>

Королькова Марія Василівна; Korolkova Mariya, ORCID: <https://orcid.org/0000-0002-3546-6279>

Дмітрієва Світлана Юріївна; Dmitrieva Svetlana, ORCID: <https://orcid.org/0000-0003-2288-3775>

Received October 03, 2019

Accepted November 21, 2019